

## BS40

- Binario Slak L = 2/3/5 mt.
- Vía "Slak" L = 2/3/5 mt.
- Slak rail L = 2/3/5 mt.
- Schiene Slak L = 2/3/5 mt.

Il binario ha una foratura con passo standard. In caso di taglio potrebbe essere necessario eseguire una foratura ad hoc.

La vía tiene un agujero de "paso" estándar. Cuando corte, deba ejecutar una perforación especial.

The rail has holes with standard spacing. In case of cut, it could be necessary to realize holes ad hoc.

Die Schiene hat Bohrung mit Standardstand. Im Fall von Schnitt könnte es notwendig sein, eine Bohrung ad hoc zu realisieren.

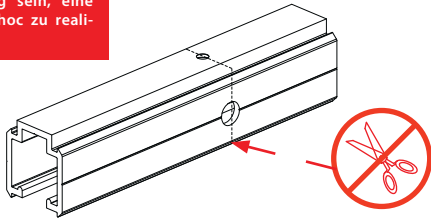
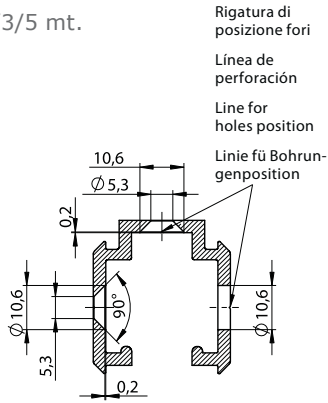

Evitare di accorciare la barra in prossimità dei fori - No acorte la barra cerca de los agujeros. - Avoid to make the bar shorter near the holes - Die Schiene in der Nähe der Bohrungen nicht abkürzen.

## BS45

- Veletta Slak L = 2/3/5 mt.
- Charter "Slak" L = 2/3/5 mt.
- Slak spandrel panel L = 2/3/5 mt.
- Anlauf Slak L = 2/3/5 mt.

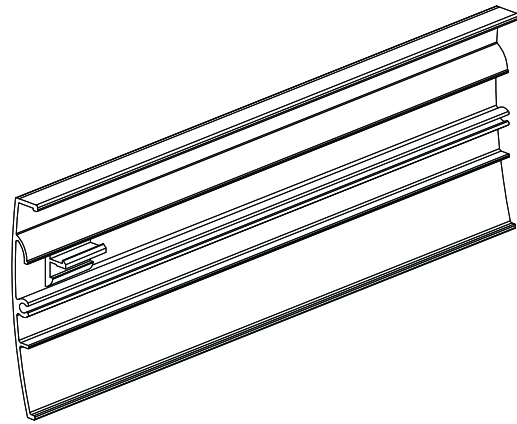
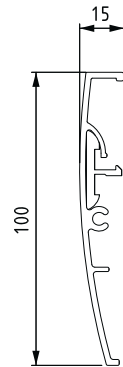

## BS60

- Coppia tappi laterali Slak.
- Pareja de tapas laterales Slak.
- Slak double covers.
- Paar Deckel Slak.

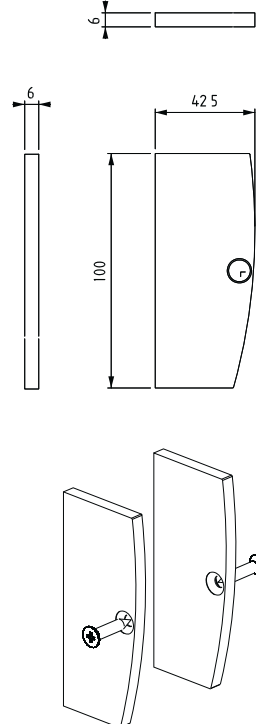

## BS61

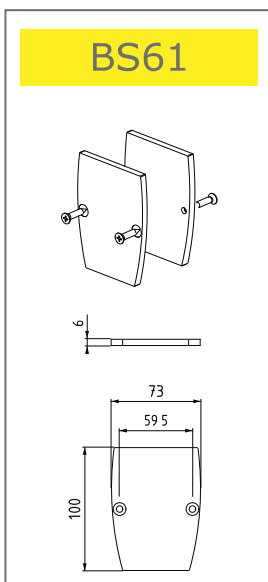

## BS70

- Supporto fisso Slak L = 300 mm .
- Soporte Slak de fijo de L = 300 mm .
- Slak fixed support L = 300 mm .
- Schiene für feste Gehäuse L = 300 mm .

