

# FLUIDO+



[colcomgroup.it](http://colcomgroup.it)

follow us on [f](#) [i](#) [y](#) [in](#)



Colcom è leader mondiale nel segmento di mercato di fascia alta nella fornitura di soluzioni architettoniche in vetro per esterni e interni. La leadership nella fascia di alto livello è garantita anche da brevetti innovativi.

Colcom is a world leader in the high-end segment of glass architectural solutions for indoor and outdoor applications. Our leadership in the high-end segment is guaranteed by innovative patents.

## **Sistemi scorrevoli invisibili e compatti**

*Invisibile and compact  
sliding systems*



# FLUIDO+

## COMPATTO, VERSATILE

COMPACT, VERSATILE

Fluido+ 70, 110, 150 e Telescopico sono i nuovi sistemi scorrevoli compatti per porte in vetro temperato. Le pareti buie appartengono al passato, le esigenze di oggi sono trasparenza e spazi ampi. La meccanica indistruttibile dei sistemi Fluido+ si fonde perfettamente con il design moderno, garantendo sicurezza, privacy e luminosità. Progettato per soddisfare le richieste del mercato, è adatto per applicazioni: a muro, a soffitto e falso soffitto. Nella versione a falso soffitto il meccanismo è completamente nascosto.

Fluido+ 70, 110, 150 and Telescopico are our latest compact sliding systems for tempered glass doors. Dark walls belong to the past: modern needs are clarity and ample spaces. The resistant mechanics of Fluido+ systems blends perfectly with their modern design, allowing security, privacy and brightness. Conceived to respond market needs, they are suitable for wall, ceiling and false ceiling installations. In the false ceiling version, the sliding mechanism is completely hidden.

- Nuovo sistema di chiusura progressiva - CPCS
- Antishock disponibile
- Regolazione frontale dell'anta semplificata e rapida
- Portata fino 150 kg
- Aggancio rapido tra veletta e binario
- Disponibile la versione per porte in legno

- New CPCS progressive closing system
- Antishock available
- Front adjustment of the door: simple and quick
- Capacity up to 150 kg
- Quick coupling of sliding rail and cover
- Available for wooden doors

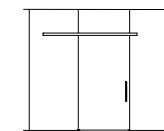

A VETRO  
On glass

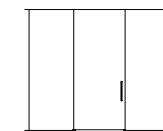

A FALSO SOFFITTO  
False ceiling

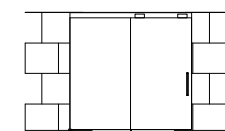

TRA PARETI  
Between walls







## Colcom Progressive Closing System

### FUNZIONALE, SICURO

*FUNCTIONAL, SECURE*

Fluido+ integra il nuovo sistema Colcom di chiusura progressiva “Colcom Progressive Closing System”(CPCS); combinando il design minimale alla massima funzionalità. E' l'accessorio che permette una chiusura automatica e graduale della porta.

Il sistema antishock integrato rallenta la corsa della porta nell'ultimo tratto di chiusura, evitando situazioni di pericolo. Non modifica l'estetica della porta poiché è invisibile dall'esterno; può essere applicato anche su ante in legno. Si installa facilmente e velocemente in ambienti sia residenziali che commerciali.

Fluido+ features the new closing system “Colcom Progressive Closing System” (CPCS); combining minimal design and maximum functionality. The accessory allows an automatic and gradual closing of the door.

The integrated antishock system slows the movement of the door in the last section, avoiding dangerous situation. It does not modify the door's aesthetics because it is invisible from outside; can be mounted on wooden doors as well. The system is easily and quickly installed in both commercial and residential environments.

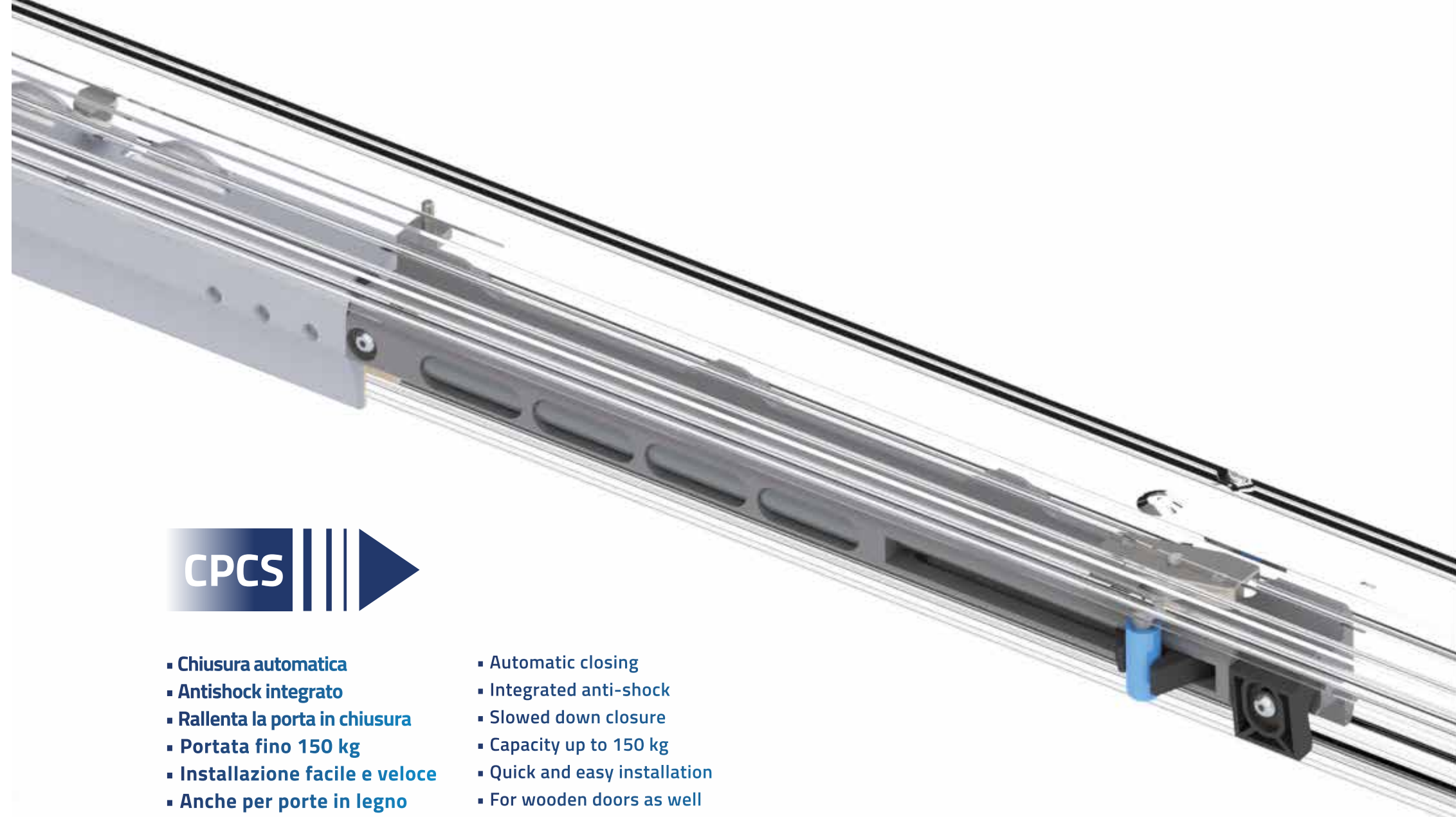

- Chiusura automatica
- Antishock integrato
- Rallenta la porta in chiusura
- Portata fino 150 kg
- Installazione facile e veloce
- Anche per porte in legno

- Automatic closing
- Integrated anti-shock
- Slowed down closure
- Capacity up to 150 kg
- Quick and easy installation
- For wooden doors as well



# FLUIDO+ 70

## CARATTERISTICHE CHARACTERISTICS

PESO PER PORTA - WEIGHT FOR DOOR: 70kg

VETRO - GLASS: 8÷12mm

LEGNO - WOOD: 28÷50mm

LUNGHEZZA - LENGHT: 2, 3, 4 e 6 metri

## CARATTERISTICHE DURABILITY

100.000 CICLI - GRADO 6

## FINITURE COLORS

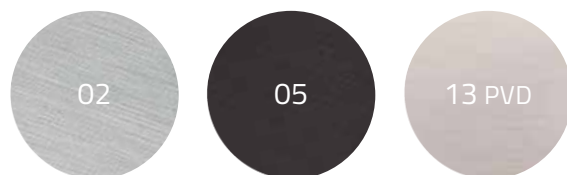

**Installazioni porte in vetro e caratteristiche tecniche profili**  
*Glass doors installation and profiles technical characteristics*

**SCORREVOLE A SOFFITTO**  
 Sliding on Ceiling

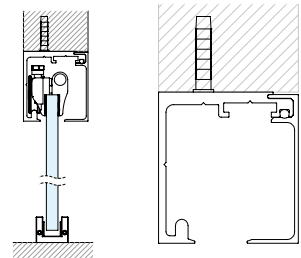
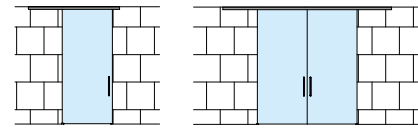

60 x 55.5 mm

**SCORREVOLE A PARETE**  
 Sliding on Wall

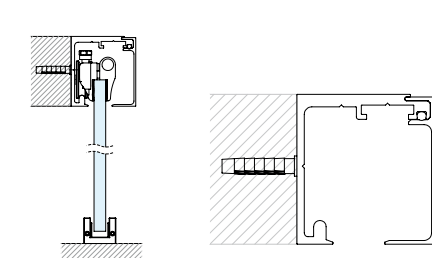
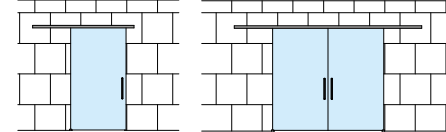

60 x 55.5 mm

**SCORREVOLE SU VETRO FISSO**  
 Sliding on Sidelight

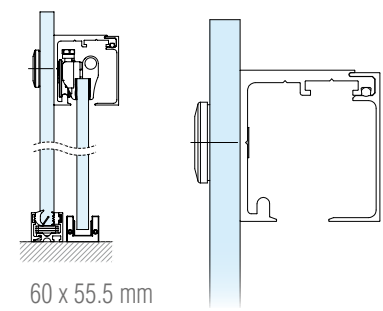
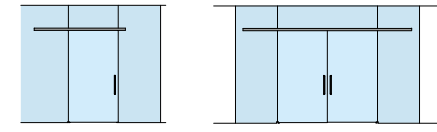

60 x 55.5 mm

**SCORREVOLE A SOFFITTO CON FISSO**  
 Sliding on Ceiling with Sidelight

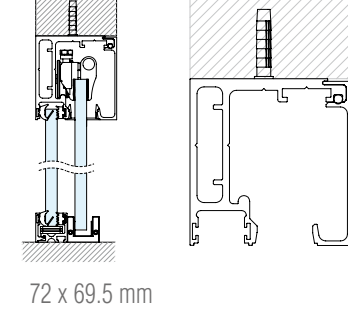
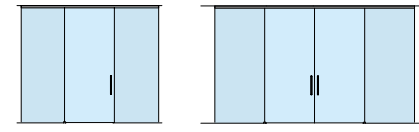

72 x 69.5 mm

**INSTALLAZIONE CON SUPPORTO A PARETE**  
 Installation with Supports on Wall

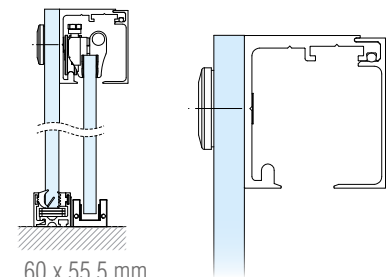
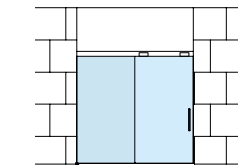

60 x 55.5 mm

**INSTALLAZIONE CON SUPPORTO A PARETE**  
 Installation with Supports on Wall

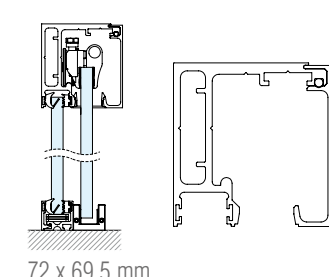
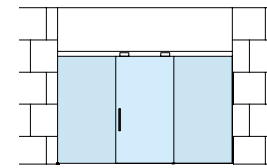

72 x 69.5 mm

**SCORREVOLE A FALSO SOFFITTO**  
 Sliding on False Ceiling

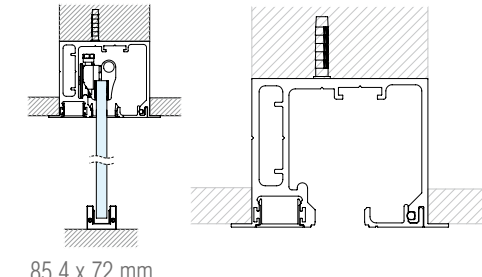
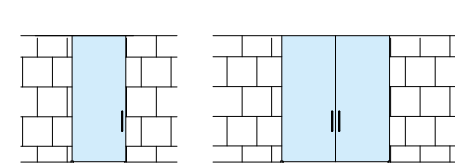

85,4 x 72 mm

**SCORREVOLE A FALSO SOFFITTO CON FISSO**  
 Sliding on False Ceiling with Sidelight

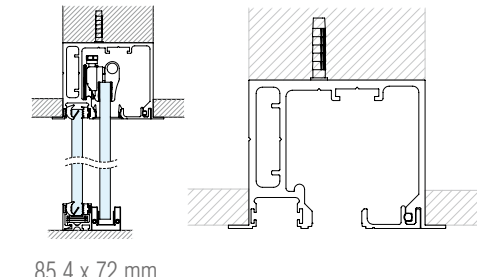
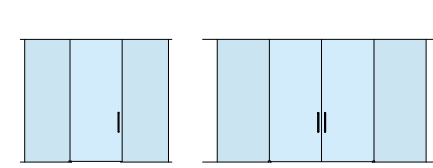

85,4 x 72 mm

**Installazioni porte in legno e caratteristiche tecniche profili**  
*Wooden doors installation and profiles technical characteristics*

**SCORREVOLE A SOFFITTO**  
 Sliding on Ceiling

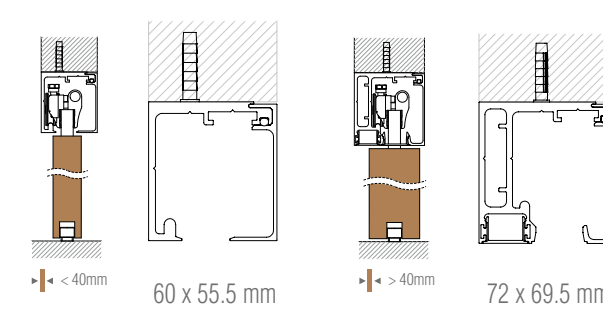
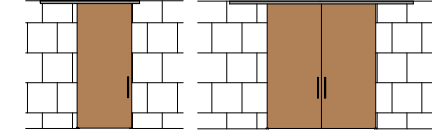

• < 40mm

60 x 55.5 mm

• > 40mm

72 x 69.5 mm

**SCORREVOLE A PARETE**  
 Sliding on Wall

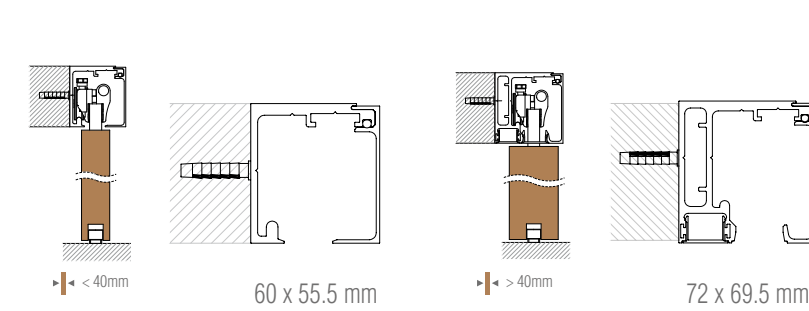
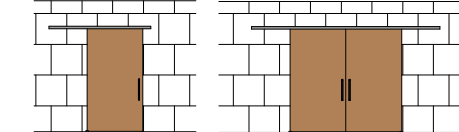

• < 40mm

60 x 55.5 mm

• > 40mm

72 x 69.5 mm

**SCORREVOLE A SOFFITTO CON FISSO**  
 Sliding on Ceiling with Sidelight

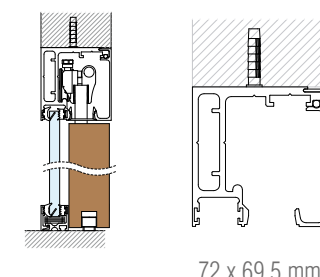
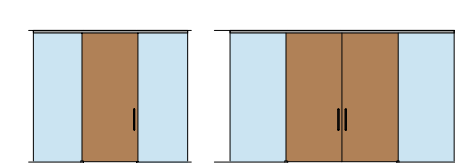

72 x 69.5 mm







## Caratteristiche Tecniche

### Technical features

|   |                                     |
|---|-------------------------------------|
|  <b>PORTATA</b><br>Weight  | 70kg per porta / for door<br>154lbs |
|  <b>SPESORE VETRO</b><br>Glass thickness                                       | 8 ÷ 12 mm<br>5/16" to 1/2"          |
|  <b>SPESORE PORTA IN LEGNO</b><br>Wooden door thickness                        | 28 ÷ 50 mm<br>1 1/8" to 1 15/16"    |
|  <b>REGOLAZIONE IN ALTEZZA</b><br>Height adjustment                            | ± 3 mm<br>1/8"                      |
|  <b>DISTANZA A PARETE</b><br>Wall distance                                     | 19 mm<br>3/4"                       |
|  <b>DISTANZA TRA ANTA E VETRO FISSO</b><br>Distance between door and sidelight | 14.2 ÷ 16.2 mm<br>9/16" to 5/8"     |

|   |   |
|---|---|
|  <b>INSTALLAZIONE A VETRO</b><br>Glass installation                  | ✓ |
|  <b>INSTALLAZIONE A FALSO SOFFITTO</b><br>False ceiling installation | ✓ |
|  <b>INSTALLAZIONE TRA PARETI</b><br>Installation between walls       | ✓ |

|   |   |   |   |
|---|---|---|---|
|  <b>SOFTCLOSE</b><br>Soft close  | Doppio / Double                                 |   |   |
|  <b>DIMENSIONI MINIME (doppio Softclose)</b><br>Minimum dimensions (double soft close) | 660 mm<br>26"                                   |   |   |
|  <b>RETAINER MECCANICO</b><br>Mechanical retainer                                      | Doppio / Double                                 |   |   |
|  <b>DIMENSIONI MINIME (doppio Retainer)</b><br>Minimum dimensions (double Retainer)    | 450 mm<br>17 11/16"                             |   |   |
|  <b>FINITURE</b><br>Finishes   | <b>02</b> Ossidato naturale<br>Natural oxidized | <b>05</b> Ossidato nero<br>Black oxidized | <b>13</b> PVD simil inox<br>similar PVD stainless steel |

|  |   |
|--|---|
|  <b>CERTIFICAZIONE DURABILITÀ</b><br>Durability certification | <b>CICLI CORROSIONE</b><br>Corrosion cycles |
|--|---|

|  |
|--|
| <b>DURABILITÀ (100.000 Cicli)</b><br>Durability (100.000 Cycles)   |
| <b>PESO DELLA PORTA (da 51 a 100 kg)</b><br>Door mass (from 51 up to 100 kg)                               |
| <b>SICUREZZA (Grado 1 per tutti gli scorrevoli)</b><br>Safety (All sliding must be grade 1)                |
| <b>RESISTENZA ALLA CORROSIONE (Alta resistenza)</b><br>Corrosion resistance (High resistance)              |
| <b>CATEGORIA DELLA PORTA (Porta scorrevole)</b><br>Category of door (Sliding door)                         |
| <b>FRIZIONE INIZIALE VALORE MASSIMO CONSENTITO (40N)</b><br>Initial friction maximum permitted value (40N) |

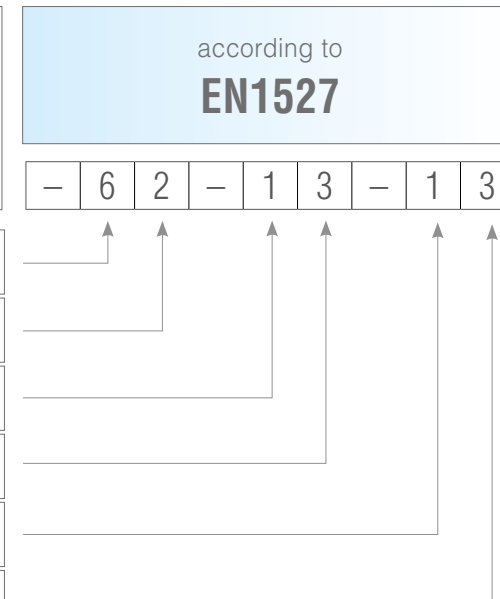

## Configurazioni kit

### Configurations kit

#### KB070CS0/2 KB070CS0/3

- Kit scorrevole parete/soffitto con doppio soft-close.
- Sliding wall / ceiling kit with double soft-close

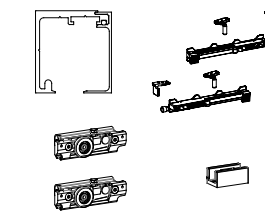

TAPPI NON INCLUSI - CAPS NOT INCLUDED

#### KB070CM0/2 KB070CM0/3

- Kit scorrevole parete/soffitto con retainer e stop meccanico.
- Sliding wall / ceiling kit with retainer and mechanical stop

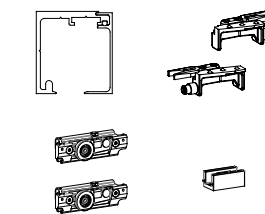

TAPPI NON INCLUSI - CAPS NOT INCLUDED

#### KB070SS0/2 KB070SS0/3

- Kit scorrevole su vetro fisso con doppio soft-close.
- Sliding kit on fixed glass with double soft-close

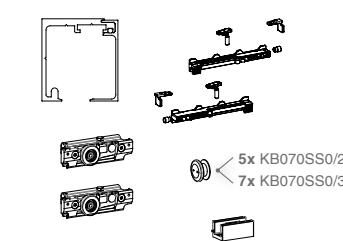

TAPPI NON INCLUSI - CAPS NOT INCLUDED

#### KB070SM0/2 KB070SM0/3

- Kit scorrevole su vetro fisso con retainer e stop meccanico.
- Sliding kit on fixed glass with retainer and mechanical stop

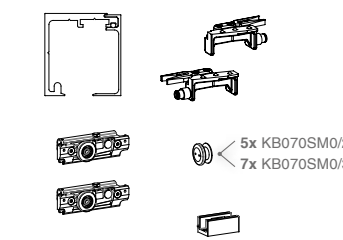

TAPPI NON INCLUSI - CAPS NOT INCLUDED

#### KB070FS0/2 KB070FS0/3

- Kit scorrevole a soffitto con fisso, con doppio soft-close.
- Fixed sliding ceiling kit with double soft-close

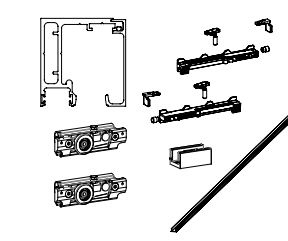

TAPPI NON INCLUSI - CAPS NOT INCLUDED

#### KB070FM0/2 KB070FM0/3

- Kit scorrevole a soffitto con fisso, con retainer e stop meccanico.
- Sliding ceiling kit with fixed, with retainer and mechanical stop

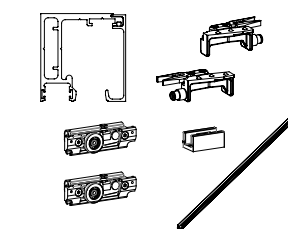

TAPPI NON INCLUSI - CAPS NOT INCLUDED

#### KB070TS5/2 KB070TS5/3

- Kit scorrevole falso soffitto con doppio soft-close.
- Sliding kit on false ceiling with double soft-close.

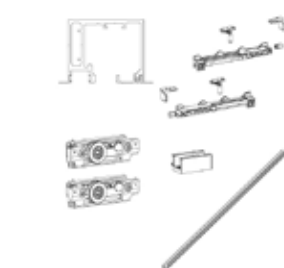

#### KB070GS5/2 KB070GS5/3

- Kit scorrevole falso soffitto con fisso con doppio soft-close.
- Sliding kit on false ceiling with fixed glass with double soft-close.

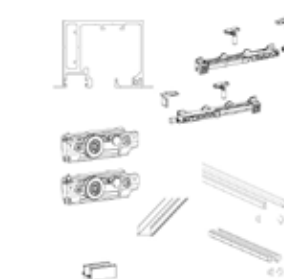



## Profili Profiles

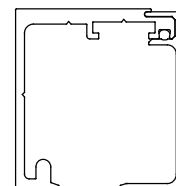

- Profili per scorrevole  
- fissaggio a soffitto/parete.  
**Anche per porte in legno < 40mm**

- Profiles for sliders  
- fixed on ceiling/wall.  
**Anche per porte in legno < 40mm**

|                   |     |
|-------------------|-----|
| <b>B110EK00/2</b> | 2 m |
| <b>B110EK00/3</b> | 3 m |
| <b>B110EK00/4</b> | 4 m |
| <b>B110EK00/6</b> | 6 m |

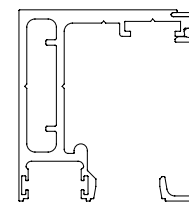

- Profili per scorrevole  
- fissaggio a soffitto con vetro fisso.  
- **fissaggio a soffitto con fisso per porta in legno**  
- **fissaggio a parete per porta in legno > 40mm**

- Profiles for sliders  
- fixed on ceiling with fixed glass  
- **fissaggio a soffitto con fisso per porta in legno**  
- **fissaggio a parete per porta in legno > 40mm**

|                   |     |
|-------------------|-----|
| <b>B110EK01/2</b> | 2 m |
| <b>B110EK01/3</b> | 3 m |
| <b>B110EK01/4</b> | 4 m |
| <b>B110EK01/6</b> | 6 m |

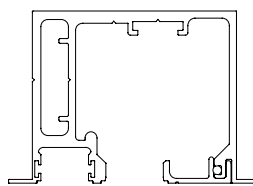

- Profili per scorrevole  
- fissaggio a falso soffitto  
- fissaggio a falso soffitto con vetro fisso.

- Kit profiles for sliders  
- fixed on false ceiling  
- fixed on false ceiling with fixed glass

|                     |       |
|---------------------|-------|
| <b>B150EK02/2</b>   | 2 m   |
| <b>B0150EK02/3</b>  | 3 m   |
| <b>B150EK02/3.2</b> | 3,2 m |
| <b>B150EK02/4</b>   | 4 m   |
| <b>B150EK02/6</b>   | 6 m   |



## Kit pinze Clamps kit



### B070EK10

- Kit coppia pinze.
- Kit with Clamps.

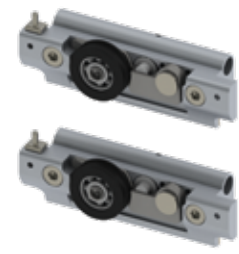

### B070EK05

- Kit coppia pinze falso soffitto
- Kit with pair of clamps on false ceiling.



### B150EK3NN

- Kit coppia Retainer. Stop meccanico
- Kit with pair of mechanical stops



### B070EK3SS

- Kit coppia Soft Close CPCS
- Kit with Soft Close CPCS pair



## Tappi Caps

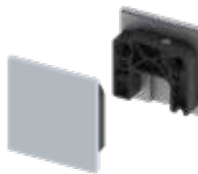

### B110EK66

- Coppia di tappi
- Pair of caps



### B110EK67

- Coppia di tappi per versione con fisso laterale
- Pair of caps for model with side fixed glass

## Accessori Accessories



### B150EK68

- Spessore per veletta e supporti laterali
- Consigliato per binari oltre i 2,5m
- Space for casing and side fittings
- Recommended for rails longer than



### B150EP48

- Tassello di collegamento per vetro fisso
- Splice connector for fixed glass



### BF50

- Guida a terra.
- Floor Guide



### B150EP85

- Kit accessorio per porte in legno
- Accessory kit for wooden doors



### BF70

- Borchia per fissaggio barra a vetro
- Fitting for securing track to glassbar



### B150EP27

- Perno per porte battenti da applicare ad estrusi Fluido+
- Spindle for swing doors, to be applied to Fluido+ profiles

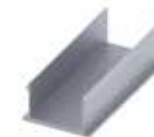

### B150EP45

- Copertura lato fisso
- Cover fixed panel



### B150EP46

- Copertura lato porta
- Cover door side

# FLUIDO+ 110

## CARATTERISTICHE CHARACTERISTICS

PESO PER PORTA - WEIGHT FOR DOOR: 110kg

VETRO - GLASS: 10÷12.76mm

LEGNO - WOOD: 28÷50mm

LUNGHEZZA - LENGHT: 2, 3, 4 e 6 metri

## CARATTERISTICHE DURABILITY

100.000 CICLI - GRADO 6

## FINITURE COLORS

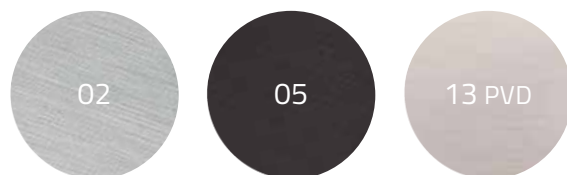



**Installazioni porte in vetro e caratteristiche tecniche profili**  
*Glass doors installation and profiles technical characteristics*

**SCORREVOLE A SOFFITTO**  
Sliding on Ceiling

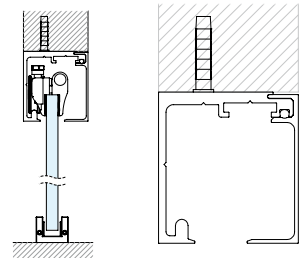
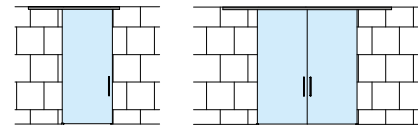

60 x 55.5 mm

**SCORREVOLE A PARETE**  
Sliding on Wall

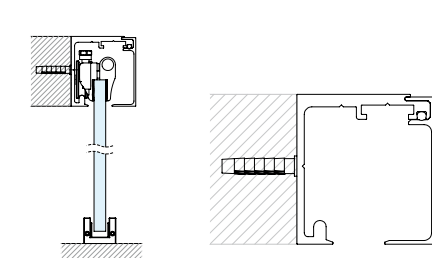
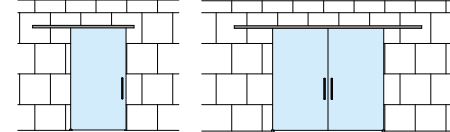

60 x 55.5 mm

**SCORREVOLE SU VETRO FISSO**  
Sliding on Sidelight

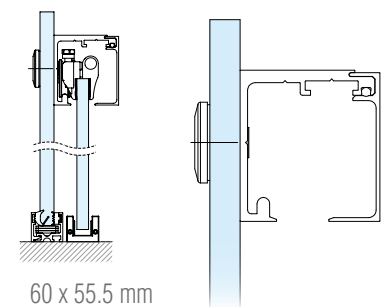
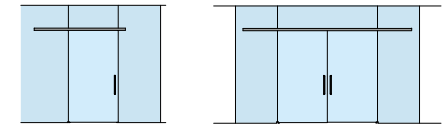

60 x 55.5 mm

**SCORREVOLE A SOFFITTO CON FISSO**  
Sliding on Ceiling with Sidelight

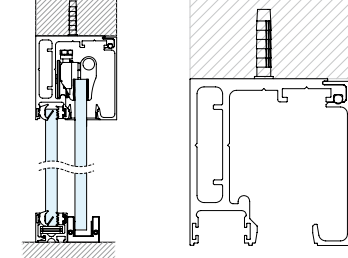
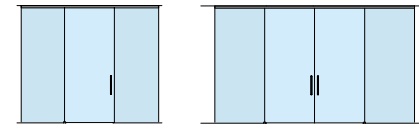

72 x 69.5 mm

**SCORREVOLE A FALSO SOFFITTO**  
Sliding on False Ceiling

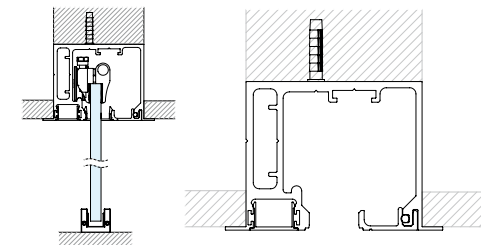
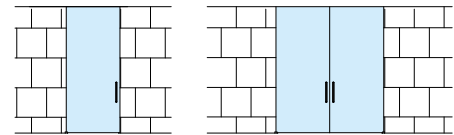

85,4 x 72 mm

**SCORREVOLE A FALSO SOFFITTO CON FISSO**  
Sliding on False Ceiling with Sidelight

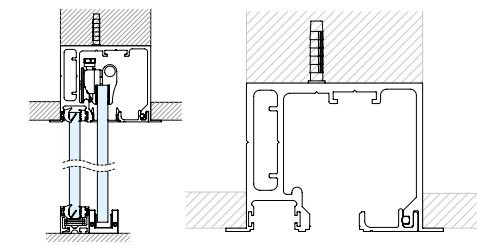
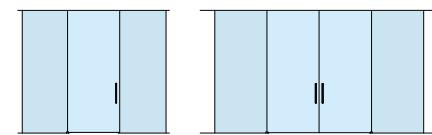

85,4 x 72 mm

**Installazioni porte in legno e caratteristiche tecniche profili**  
*Wooden doors installation and profiles technical characteristics*

**SCORREVOLE A SOFFITTO**  
Sliding on Ceiling

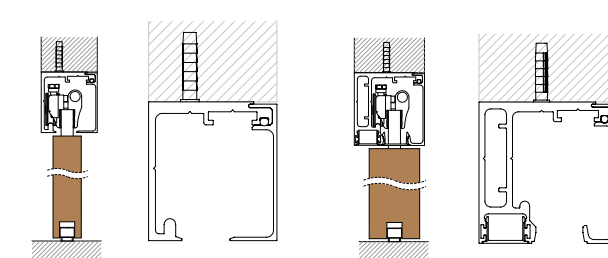
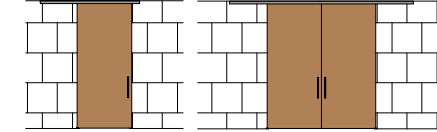

• < 40mm

60 x 55.5 mm

• > 40mm

72 x 69.5 mm

**SCORREVOLE A PARETE**  
Sliding on Wall

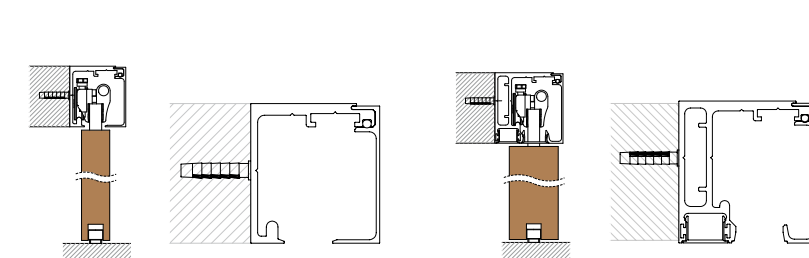
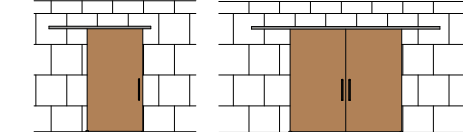

• < 40mm

60 x 55.5 mm

• > 40mm

72 x 69.5 mm

**SCORREVOLE A SOFFITTO CON FISSO**  
Sliding on Ceiling with Sidelight

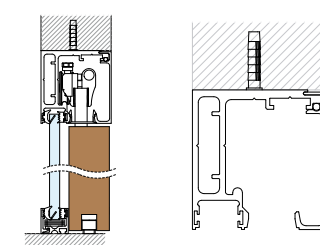
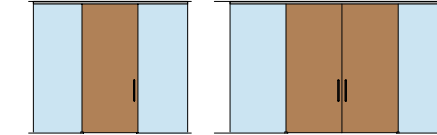

72 x 69.5 mm



## Caratteristiche Tecniche

### Technical features

|   |                                      |
|---|--------------------------------------|
|  <b>PORTATA</b><br>Weight  | 110kg per porta / for door<br>242lbs |
|  <b>SPESORE VETRO</b><br>Glass thickness                                       | 10 ÷ 12.76 mm<br>3/8" to 1/2"        |
|  <b>SPESORE PORTA IN LEGNO</b><br>Wooden door thickness                        | 28 ÷ 50 mm<br>1 1/8" to 1 15/16"     |
|  <b>REGOLAZIONE IN ALTEZZA</b><br>Height adjustment                            | ± 3 mm<br>1/8"                       |
|  <b>DISTANZA A PARETE</b><br>Wall distance                                     | 20 mm<br>13/16"                      |
|  <b>DISTANZA TRA ANTA E VETRO FISSO</b><br>Distance between door and sidelight | 14.8 ÷ 16.2 mm<br>9/16" to 5/8"      |

|   |   |
|---|---|
|  <b>INSTALLAZIONE A VETRO</b><br>Glass installation                  | ✓ |
|  <b>INSTALLAZIONE A FALSO SOFFITTO</b><br>False ceiling installation | ✓ |
|  <b>INSTALLAZIONE TRA PARETI</b><br>Installation between walls       | ✓ |

|  |   |
|--|---|
|  <b>SOFTCLOSE</b><br>Soft close   | Doppio / Double   |
|  <b>DIMENSIONI MINIME (doppio Softclose)</b><br>Minimum dimensions (double soft close) | 922 mm<br>36 1/4"   |
|  <b>ANTISHOCK</b><br>Antishock  | Doppio / Double   |
|  <b>DIMENSIONI MINIME (doppio antishock)</b><br>Minimum dimensions (double antishock) | 700 mm<br>27 9/16"  |
|  <b>RETAINER MECCANICO</b><br>Mechanical retainer                                     | Doppio / Double   |
|  <b>DIMENSIONI MINIME (doppio Retainer)</b><br>Minimum dimensions (double Retainer)   | 700 mm<br>27 9/16"  |
|  <b>FINITURE</b><br>Finishes  | <b>02</b> Ossidato naturale<br>Natural oxidized <b>05</b> Ossidato nero<br>Black oxidized <b>13</b> PVD simil inox<br>similar PVD stainless steel |

 **CERTIFICAZIONE DURABILITÀ**  
**CICLI CORROSIONE**  
Durability certification  
Corrosion cycles

according to  
**EN1527**

- 6 3 - 1 3 - 1 3

**DURABILITÀ (100.000 Cicli)**  
Durability (100.000 Cycles)

**PESO DELLA PORTA (da 101 a 330 kg)**  
Door mass (from 101 up to 330 kg)

**SICUREZZA (Grado 1 per tutti gli scorrevoli)**  
Safety (All sliding must be grade 1)

**RESISTENZA ALLA CORROSIONE (Alta resistenza)**  
Corrosion resistance (High resistance)

**CATEGORIA DELLA PORTA (Porta scorrevole)**  
Category of door (Sliding door)

**FRIZIONE INIZIALE VALORE MASSIMO CONSENTITO (4% della massa)**  
Initial friction maximum permitted value (4% of the mass)

## Configurazioni kit

### Configurations kit

#### KB110CS0/2 - KB110CS0/3

- Kit scorrevole parete/soffitto con doppio soft-close.
- Sliding wall / ceiling kit with double soft-close

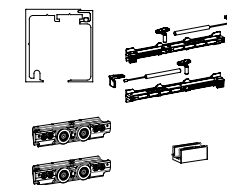

TAPPI NON INCLUSI - CAPS NOT INCLUDED

#### KB110CM0/2 - KB110CM0/3

- Kit scorrevole parete/soffitto con retainer e stop meccanico.
- Sliding wall / ceiling kit with retainer and mechanical stop

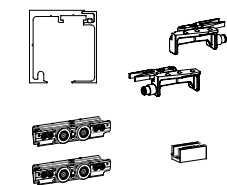

TAPPI NON INCLUSI - CAPS NOT INCLUDED

#### KB110CA0/2 - KB110CA0/3

- Kit scorrevole parete/soffitto con retainer e antishock.
- Sliding wall / ceiling kit with retainer and Antishock

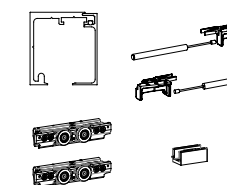

TAPPI NON INCLUSI - CAPS NOT INCLUDED

#### KB110SS0/2 - KB110SS0/3

- Kit scorrevole su vetro fisso con doppio soft-close.
- Sliding kit on fixed glass with double soft-close

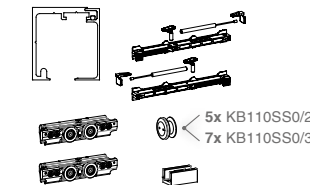

TAPPI NON INCLUSI - CAPS NOT INCLUDED

#### KB110SM0/2 - KB110SM0/3

- Kit scorrevole su vetro fisso con retainer e stop meccanico.
- Sliding kit on fixed glass with retainer and mechanical stop

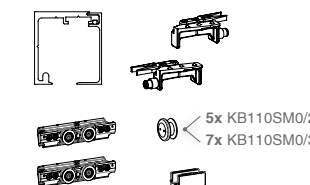

TAPPI NON INCLUSI - CAPS NOT INCLUDED

#### KB110SA0/2 - KB110SA0/3

- Kit scorrevole su vetro fisso con retainer e antishock.
- Sliding kit on fixed glass with retainer and Antishock

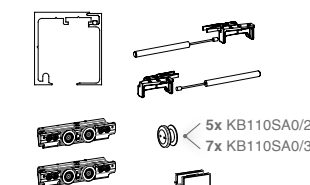

TAPPI NON INCLUSI - CAPS NOT INCLUDED

#### KB110FS0/2 - KB110FS0/3

- Kit scorrevole a soffitto con fisso con doppio soft-close.
- Fixed sliding ceiling kit with double soft-close

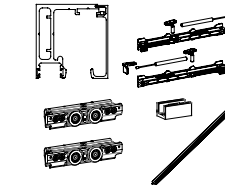

TAPPI NON INCLUSI - CAPS NOT INCLUDED

#### KB110FM0/2 - KB110FM0/3

- Kit scorrevole a soffitto con fisso con retainer e stop meccanico.
- Sliding ceiling kit with fixed, with retainer and mechanical stop

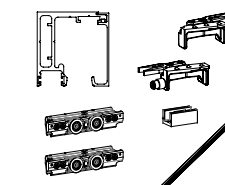

TAPPI NON INCLUSI - CAPS NOT INCLUDED

#### KB110FA0/2 - KB110FA0/3

- Kit scorrevole a soffitto con fisso con retainer e antishock.
- Sliding ceiling kit with fixed, with retainer and Antishock

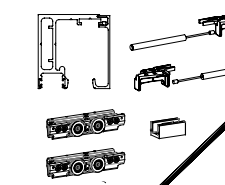

TAPPI NON INCLUSI - CAPS NOT INCLUDED

#### KB110TS5/2 - KB110TS5/3

- Kit scorrevole falso soffitto con doppio soft-close.
- Sliding kit on false ceiling with double soft-close.



#### KB110GS5/2 - KB110GS5/3

- Kit scorrevole falso soffitto con fisso con doppio soft-close.
- Sliding kit on false ceiling with fixed glass with double soft-close.

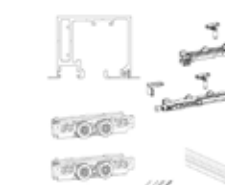

## Profili Profiles

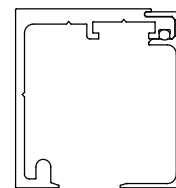

- Profili per scorrevole  
- fissaggio a soffitto/parete.  
Anche per porte in legno < 40mm

- Profiles for sliders  
- fixed on ceiling/wall.  
Anche per porte in legno < 40mm

|            |     |
|------------|-----|
| B110EK00/2 | 2 m |
| B110EK00/3 | 3 m |
| B110EK00/4 | 4 m |
| B110EK00/6 | 6 m |

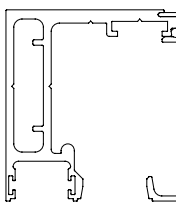

- Profili per scorrevole  
- fissaggio a soffitto con vetro fisso.  
- fissaggio a soffitto con fisso per porta in legno  
- fissaggio a parete per porta in legno > 40mm

- Profiles for sliders  
- fixed on ceiling with fixed glass  
- fissaggio a soffitto con fisso per porta in legno  
- fissaggio a parete per porta in legno > 40mm

|            |     |
|------------|-----|
| B110EK01/2 | 2 m |
| B110EK01/3 | 3 m |
| B110EK01/4 | 4 m |
| B110EK01/6 | 6 m |

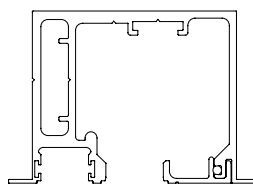

- Profili per scorrevole  
- fissaggio a falso soffitto  
- fissaggio a falso soffitto con vetro fisso.

- Kit profiles for sliders  
- fixed on false ceiling  
- fixed on false ceiling with fixed glass

|              |       |
|--------------|-------|
| B150EK02/2   | 2 m   |
| B0150EK02/3  | 3 m   |
| B150EK02/3.2 | 3,2 m |
| B150EK02/4   | 4 m   |
| B150EK02/6   | 6 m   |





## Kit pinze

### Clamps kit



#### B110EK10

- Kit coppia pinze.
- Kit with Clamps.



#### B110EK05

- Kit coppia pinze falso soffitto
- Kit with pair of clamps on false ceiling.



#### B150EK3NN

- Kit coppia Retainer. Stop meccanico
- Kit with pair of mechanical stops



#### B150EK3AA

- Kit coppia Retainer + Antishock
- Kit with pair of mechanical stops and anti-shock feature



#### B110EK3SS

- Kit coppia Soft Close CPCS
- Kit with Soft Close CPCS pair



## Tappi

### Caps

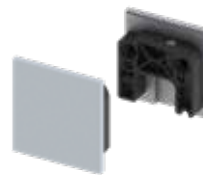

#### B110EK66

- Coppia di tappi
- Pair of caps



#### B110EK67

- Coppia di tappi per versione con fisso laterale
- Pair of caps for model with side fixed glass

## Accessori

### Accessories



#### B150EK68

- Spessore per veletta e supporti laterali
- Consigliato per binari oltre i 2,5m
- Space for casing and side fittings
- Recommended for rails longer than



#### B150EP48

- Tassello di collegamento per vetro fisso
- Splice connector for fixed glass



#### BF50

- Guida a terra.
- Floor Guide



#### B150EP85

- Kit accessorio per porte in legno
- Accessory kit for wooden doors



#### BF70

- Borchia per fissaggio barra a vetro
- Fitting for securing track to glassbar



#### B150EP27

- Perno per porte battenti da applicare ad estrusi Fluido+
- Spindle for swing doors, to be applied to Fluido+ profiles

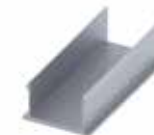

#### B150EP45

- Copertura lato fisso
- Cover fixed panel



#### B150EP46

- Copertura lato porta
- Cover door side

# FLUIDO+ 150

## CARATTERISTICHE CHARACTERISTICS

PESO PER PORTA - WEIGHT FOR DOOR: 150kg

VETRO - GLASS: 10÷14mm

LEGNO - WOOD: 28÷50mm

LUNGHEZZA - LENGTH: 2, 3, 3.2, 4 e 6 metri

## CARATTERISTICHE DURABILITY

100.000 CICLI - GRADO 6

## FINITURE COLORS

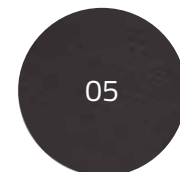

## Installazioni porte in vetro e caratteristiche tecniche profili

### Glass doors installation and profiles technical characteristics

**SCORREVOLE A SOFFITTO**  
Sliding on Ceiling

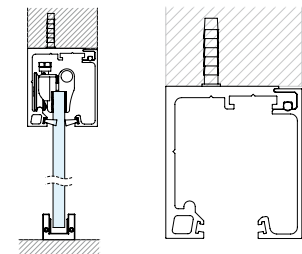
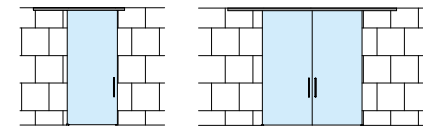

67 x 60 mm

**SCORREVOLE A PARETE**  
Sliding on Wall

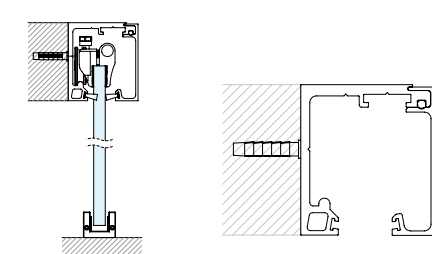
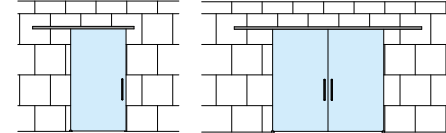

67 x 60 mm

**SCORREVOLE SU VETRO FISSO**  
Sliding on Sidelight

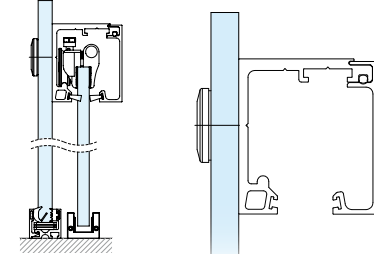
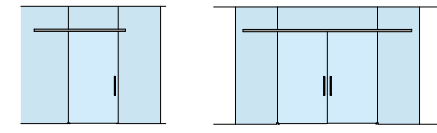

67 x 60 mm

**SCORREVOLE A SOFFITTO CON FISSO**  
Sliding on Ceiling with Sidelight

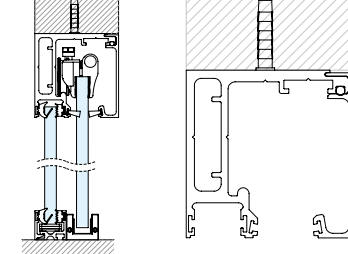
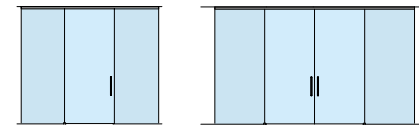

72 x 72 mm

**SCORREVOLE A FALSO SOFFITTO**  
Sliding on False Ceiling

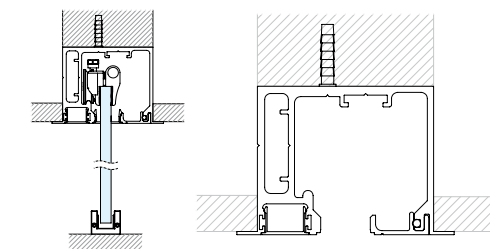
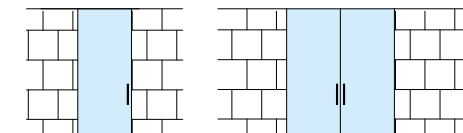

85,4 x 72 mm

**SCORREVOLE A FALSO SOFFITTO CON FISSO**  
Sliding on False Ceiling with Sidelight

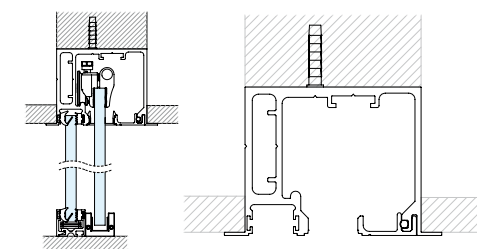
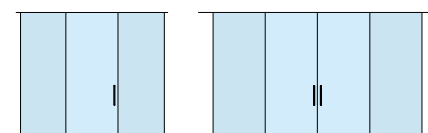

85,4 x 72 mm

## Installazioni porte in legno e caratteristiche tecniche profili

### Wooden doors installation and profiles technical characteristics

**SCORREVOLE A SOFFITTO**  
Sliding on Ceiling

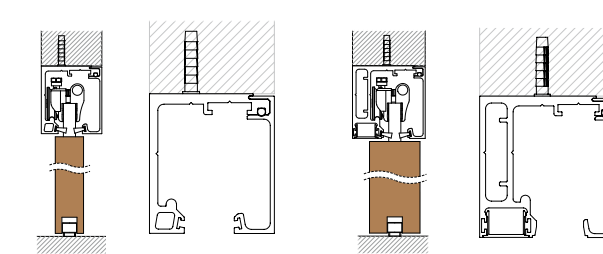
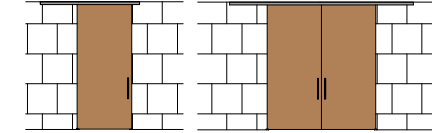

• < 40mm

67 x 70 mm

• > 40mm

72 x 72 mm

**SCORREVOLE A PARETE**  
Sliding on Wall

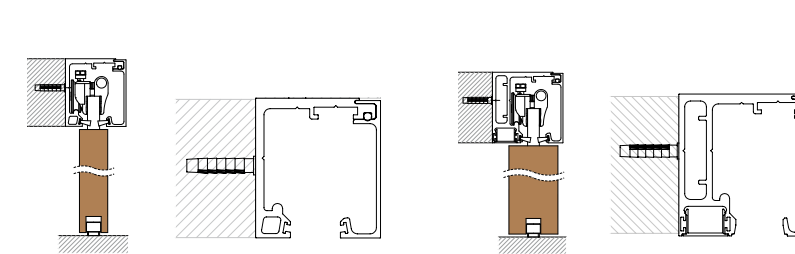
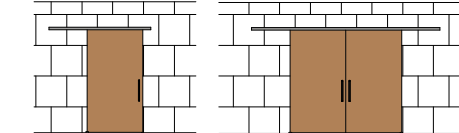

• < 40mm

67 x 70 mm

• > 40mm

72 x 72 mm

**SCORREVOLE A SOFFITTO CON FISSO**  
Sliding on Ceiling with Sidelight

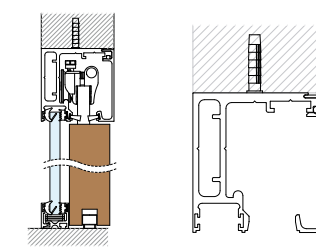
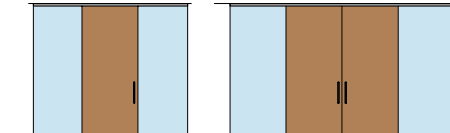

72 x 72 mm





## Caratteristiche Tecniche

### Technical features

|   |                                      |
|---|--------------------------------------|
|  <b>PORTATA</b><br>Weight  | 150kg per porta / for door<br>330lbs |
|  <b>SPESORE VETRO</b><br>Glass thickness                                       | 10 ÷ 14 mm<br>3/8" to 9/16"          |
|  <b>SPESORE PORTA IN LEGNO</b><br>Wooden door thickness                        | 28 ÷ 50 mm<br>1 1/8" to 1 15/16"     |
|  <b>REGOLAZIONE IN ALTEZZA</b><br>Height adjustment                            | ± 3 mm<br>1/8"                       |
|  <b>DISTANZA A PARETE</b><br>Wall distance                                     | 22 mm<br>7/8"                        |
|  <b>DISTANZA TRA ANTA E VETRO FISSO</b><br>Distance between door and sidelight | 15.4 ÷ 17.4 mm<br>5/8" to 11/16"     |

|   |   |
|---|---|
|  <b>INSTALLAZIONE A VETRO</b><br>Glass installation                  | ✓ |
|  <b>INSTALLAZIONE A FALSO SOFFITTO</b><br>False ceiling installation | ✓ |
|  <b>INSTALLAZIONE TRA PARETI</b><br>Installation between walls       | ✓ |

|  |   |   |   |
|--|---|---|---|
|  <b>SOFTCLOSE</b><br>Soft close   | Doppio / Double                                 |   |   |
|  <b>DIMENSIONI MINIME (doppio Softclose)</b><br>Minimum dimensions (double soft close) | 1014 mm<br>39 3/4"                              |   |   |
|  <b>ANTISHOCK</b><br>Antishock  | Doppio / Double                                 |   |   |
|  <b>DIMENSIONI MINIME (doppio antishock)</b><br>Minimum dimensions (double antishock) | 800 mm<br>31 1/2"                               |   |   |
|  <b>RETAINER MECCANICO</b><br>Mechanical retainer                                     | Doppio / Double                                 |   |   |
|  <b>DIMENSIONI MINIME (doppio Retainer)</b><br>Minimum dimensions (double Retainer)   | 800 mm<br>31 1/2"                               |   |   |
|  <b>FINITURE</b><br>Finishes  | <b>02</b> Ossidato naturale<br>Natural oxidized | <b>05</b> Ossidato nero<br>Black oxidized | <b>13</b> PVD simil inox<br>similar PVD stainless steel |

|   |                               |
|---|-------------------------------|
|  <b>CERTIFICAZIONE DURABILITÀ CICLI CORROSIONE</b><br>Durability certification<br>Corrosion cycles | according to<br><b>EN1527</b> |
| <b>DURABILITÀ (100.000 Cicli)</b><br>Durability (100.000 Cycles)  |                               |
| <b>PESO DELLA PORTA (da 101 a 330 kg)</b><br>Door mass (from 101 up to 330 kg)  |                               |
| <b>SICUREZZA (Grado 1 per tutti gli scorrevoli)</b><br>Safety (All sliding must be grade 1)   |                               |
| <b>RESISTENZA ALLA CORROSIONE (Alta resistenza)</b><br>Corrosion resistance (High resistance)   |                               |
| <b>CATEGORIA DELLA PORTA (Porta scorrevole)</b><br>Category of door (Sliding door)  |                               |
| <b>FRIZIONE INIZIALE VALORE MASSIMO CONSENTITO (4% della massa)</b><br>Initial friction maximum permitted value (4% of the mass)  |                               |

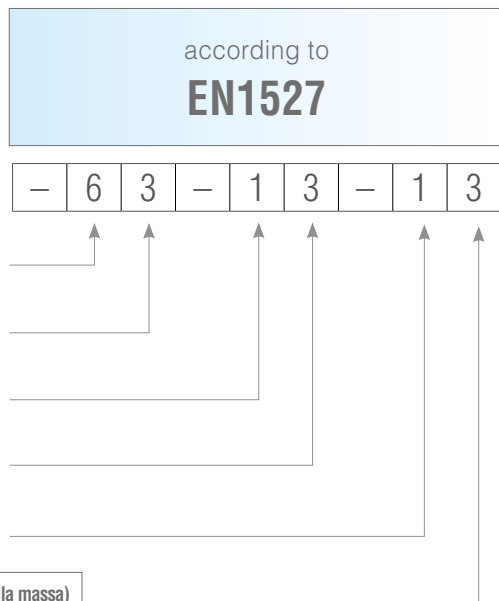

## Configurazioni kit

### Configurations kit

#### KB150CS0/3.2

• Kit scorrevole parete/soffitto con doppio soft-close.

• Sliding wall / ceiling kit with double soft-close

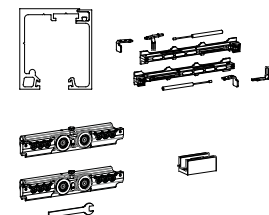

TAPPI NON INCLUSI - CAPS NOT INCLUDED

#### KB150CM0/3.2

• Kit scorrevole parete/soffitto con retainer e stop meccanico.

• Sliding wall / ceiling kit with retainer and mechanical stop

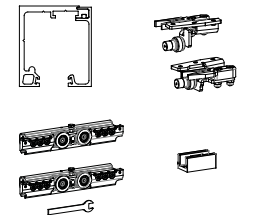

TAPPI NON INCLUSI - CAPS NOT INCLUDED

#### KB150CA0/3.2

• Kit scorrevole parete/soffitto con retainer e antishock.

• Sliding wall / ceiling kit with retainer and Antishock

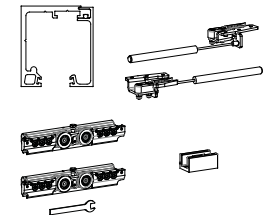

TAPPI NON INCLUSI - CAPS NOT INCLUDED

#### KB150SS0/3.2

• Kit scorrevole su vetro fisso con doppio soft-close.

• Sliding kit on fixed glass with double soft-close

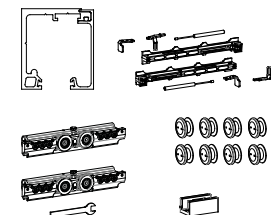

TAPPI NON INCLUSI - CAPS NOT INCLUDED

#### KB150SM0/3.2

• Kit scorrevole su vetro fisso con retainer e stop meccanico.

• Sliding kit on fixed glass with retainer and mechanical stop

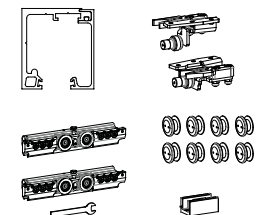

TAPPI NON INCLUSI - CAPS NOT INCLUDED

#### KB150SA0/3.2

• Kit scorrevole su vetro fisso con retainer e antishock.

• Sliding kit on fixed glass with retainer and Antishock

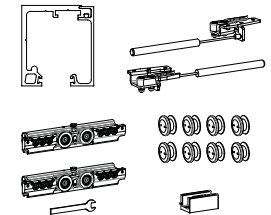

TAPPI NON INCLUSI - CAPS NOT INCLUDED

#### KB150FS0/3.2

• Kit scorrevole a soffitto con fisso, con doppio soft-close.

• Fixed sliding ceiling kit with double soft-close

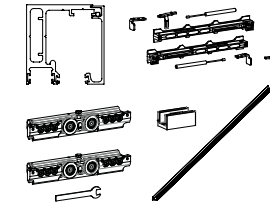

TAPPI NON INCLUSI - CAPS NOT INCLUDED

#### KB150FM0/3.2

• Kit scorrevole a soffitto con fisso, con retainer e stop meccanico.

• Sliding ceiling kit with fixed, with retainer and mechanical stop

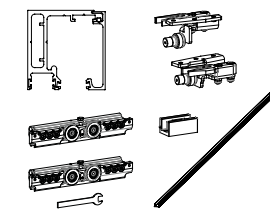

TAPPI NON INCLUSI - CAPS NOT INCLUDED

#### KB150FA0/3.2

• Kit scorrevole a soffitto con fisso, con retainer e antishock.

• Sliding ceiling kit with fixed, with retainer and Antishock

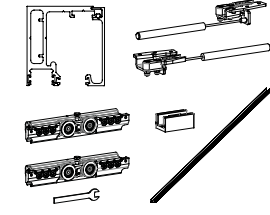

TAPPI NON INCLUSI - CAPS NOT INCLUDED

## Profili

### Profiles

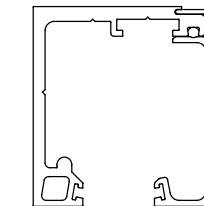

• Profili per scorrevole  
- fissaggio a soffitto/parete.  
Anche per porte in legno < 40mm

• Profiles for sliders  
- fixed on ceiling/wall.  
Anche per porte in legno < 40mm

|                     |       |
|---------------------|-------|
| <b>B150EK00/2</b>   | 2 m   |
| <b>B150EK00/3</b>   | 3 m   |
| <b>B150EK00/3.2</b> | 3,2 m |
| <b>B150EK00/4</b>   | 4 m   |
| <b>B150EK00/6</b>   | 6 m   |

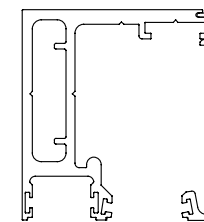

• Profili per scorrevole  
- fissaggio a soffitto con vetro fisso.  
- fissaggio a soffitto con fisso per porta in legno  
- fissaggio a parete per porta in legno > 40mm

• Profiles for sliders  
- fixed on ceiling with fixed glass  
- fissaggio a soffitto con fisso per porta in legno  
- fissaggio a parete per porta in legno > 40mm

|                     |       |
|---------------------|-------|
| <b>B150EK01/2</b>   | 2 m   |
| <b>B0150EK01/3</b>  | 3 m   |
| <b>B150EK01/3.2</b> | 3,2 m |
| <b>B150EK01/4</b>   | 4 m   |
| <b>B150EK01/6</b>   | 6 m   |

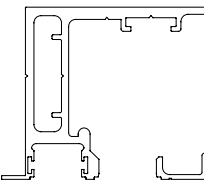

• Profili per scorrevole  
- fissaggio a falso soffitto  
- fissaggio a falso soffitto con vetro fisso.

• Kit profiles for sliders  
- fixed on false ceiling  
- fixed on false ceiling with fixed glass

|                     |       |
|---------------------|-------|
| <b>B150EK02/2</b>   | 2 m   |
| <b>B0150EK02/3</b>  | 3 m   |
| <b>B150EK02/3.2</b> | 3,2 m |
| <b>B150EK02/4</b>   | 4 m   |
| <b>B150EK02/6</b>   | 6 m   |

## Kit pinze

### Clamps kit



#### B150EK10

- Kit coppia pinze.
- Kit with Clamps.



#### B150EK05

- Kit coppia pinze falso soffitto
- Kit with pair of clamps on false ceiling.

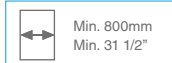

#### B150EK3NN

- Kit coppia Retainer. Stop meccanico
- Kit with pair of mechanical stops



#### B150EK3AA

- Kit coppia Retainer + Antishock
- Kit with pair of mechanical stops and anti-shock feature

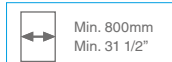

#### B150EK3SS

- Kit coppia Soft Close CPCS
- Kit with Soft Close CPCS pair

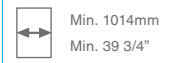

## Tappi

### Caps



#### B150EK66

- Coppia di tappi
- Pair of caps



#### B150EK67

- Coppia di tappi per versione con fisso laterale
- Pair of caps for model with side fixed glass

## Accessori

### Accessories



#### B150EK68

- Spessore per veletta e supporti laterali
- Consigliato per binari oltre i 2,5m
- Space for casing and side fittings
- Recommended for rails longer than



#### B150EP48

- Tassello di collegamento per vetro fisso
- Splice connector for fixed glass



#### BF50

- Guida a terra.
- Floor Guide



#### B150EP85

- Kit accessorio per porte in legno
- Accessory kit for wooden doors



#### BF70

- Borchia per fissaggio barra a vetro
- Fitting for securing track to glassbar



#### B150EP27

- Perno per porte battenti da applicare ad estrusi Fluido+
- Spindle for swing doors, to be applied to Fluido+ profiles

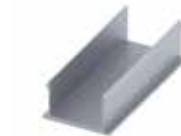

#### B150EP45

- Copertura lato fisso
- Cover fixed panel



#### B150EP46

- Copertura lato porta
- Cover door side



#### SPZ-FP

- Guarnizione a spazzola in tessuto
- Fabric brush seal



#### SPZ-FPBL

# FLUIDO+ TELESCOPICO

## CARATTERISTICHE CHARACTERISTICS

PESO PER PORTA - WEIGHT FOR DOOR: 150kg

VETRO - GLASS: 10÷14mm

LUNGHEZZA - LENGHT: 6 metri

## CARATTERISTICHE DURABILITY

100.000 CICLI - GRADO 6

## FINITURE COLORS

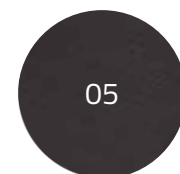



## Installazioni porte in vetro e caratteristiche tecniche profili

Glass doors installation and profiles technical characteristics

### TELESCOPICO A SOFFITTO Telescopic on Ceiling

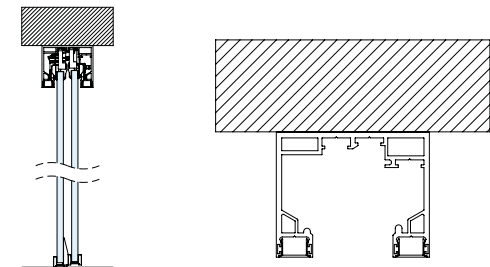
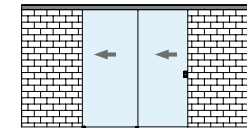

113.6 x 93 mm

### TELESCOPICO A PARETE Telescopic on Wall

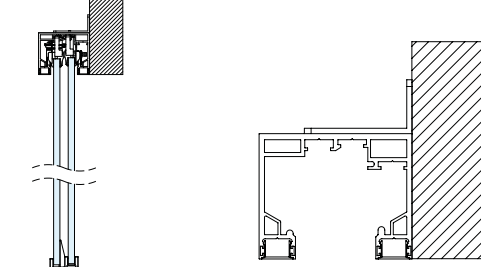
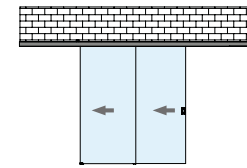

113.6 x 93 mm

### TELESCOPICO CON VETRO FISSO Telescopic with Sidelight

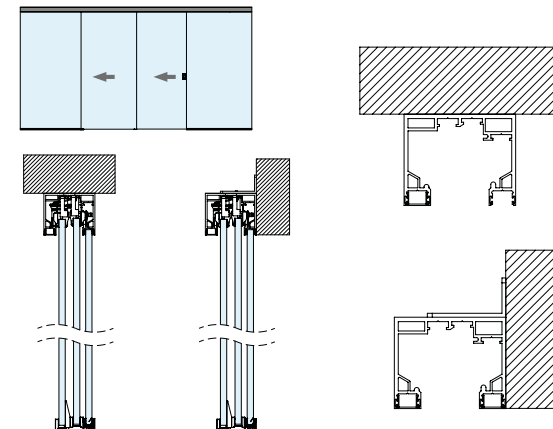

113.6 x 93 mm

### TELESCOPICO CON DOPPIO VETRO FISSO Sliding with double Sidelight

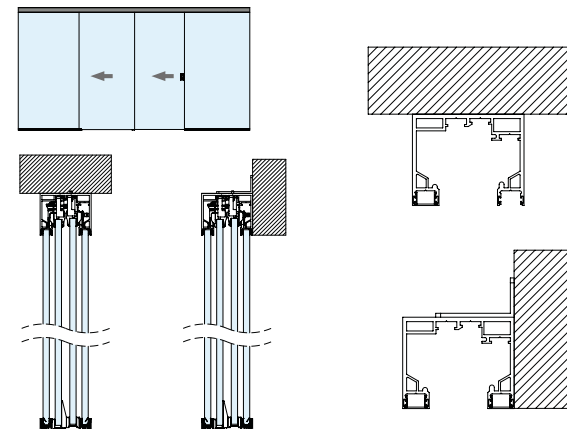

113.6 x 93 mm

## Caratteristiche Tecniche

Technical features

|   |  |   |   |
|---|--|---|---|
| <b>PORTATA MASSIMA</b><br>Max Weight  | 150kg per porta / for door<br>330lbs                         |   |   |
| <b>SPESORE VETRO</b><br>Glass thickness                                       | 10 ÷ 14 mm<br>3/8" to 9/16"                                  |   |   |
| <b>REGOLAZIONE IN ALTEZZA</b><br>Height adjustment                            | ± 3 mm<br>1/8"   |   |   |
| <b>DISTANZA A PARETE</b><br>Wall distance                                     | 33.5 mm<br>1 5/16"   |   |   |
| <b>DISTANZA TRA ANTA E VETRO FISSO</b><br>Distance between door and sidelight | 13 ÷ 15 mm<br>1/2" to 19/32"                                 |   |   |
| <b>SOFTCLOSE</b><br>Soft close  | Doppio / Double  |   |   |
| <b>DIMENSIONI MINIME</b><br>Minimum dimensions                                | B150EK05 = 1035 mm [40 3/4"]<br>B110EK05 = 945 mm [37 7/32"] |   |   |
| <b>FINITURE</b><br>Finishes   | <b>02</b> Ossidato naturale<br>Natural oxidized              | <b>05</b> Ossidato nero<br>Black oxidized | <b>13</b> PVD simil inox<br>similar PVD stainless steel |



**CERTIFICAZIONE DURABILITÀ  
CICLI CORROSIONE**  
Durability certification  
Corrosion cycles

**CATEGORIA DELLA PORTA (Porta scorrevole)**  
Category of door (Sliding door)

**PESO DELLA PORTA (100 kg)**  
Door mass (from 101 up to 330 kg)

**DIMENSIONE PORTA TEST (2m x 0,8m)**  
Size test door (2m x 0,8m)

**RESISTENZA ALLA CORROSIONE**  
Corrosion resistance

**SLAM TEST (2 kg)**  
Slam Test (2 kg)

**CARICO STATICO ORIZZONTALE (250N)**  
Horizontal static load test (250N)

**CARICO STATICO**  
Static load test

**FRIZIONE INIZIALE (30N)**  
Initial friction (30N)

**DURABILITÀ (100.000 Cicli)**  
Durability (100.000 Cycles)

according to  
**EN1527 2022**

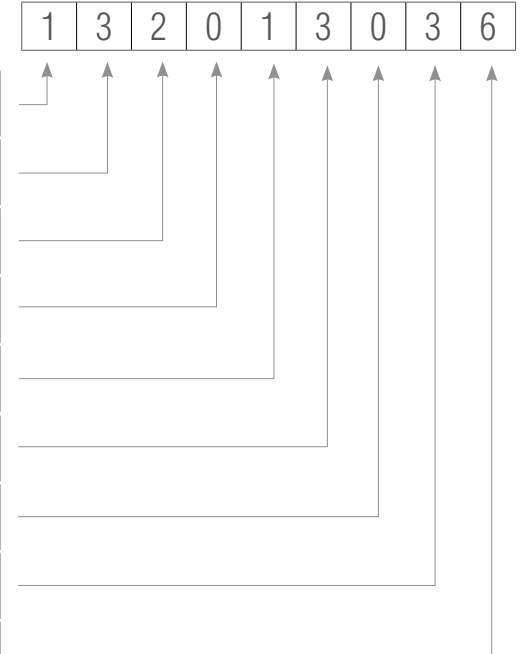



## Configurazioni kit Configurations kit

### KB150DS0/6

• Kit scorrevole telescopico a soffitto con doppio soft-close.

• Telescopic sliding ceiling kit with double soft-close.



#### TAPPI INCLUSI - CAPS INCLUDED

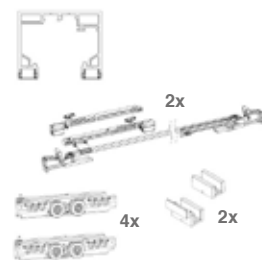

### KB150ES0/6

• Kit scorrevole telescopico a parete con doppio soft-close.

• Telescopic sliding wall kit with double soft-close.



#### TAPPI INCLUSI - CAPS INCLUDED

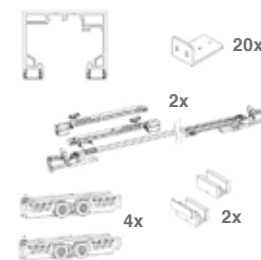

## Profili Profiles

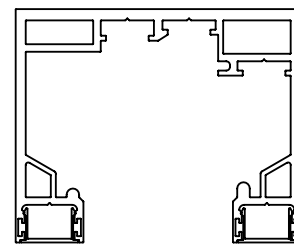

• Profilo binario per scorrevole telescopico: soffitto, parete e su vetro fisso

• Telescopic sliding profile for: ceiling, wall and sidelight installation.

**B150EK04/6** | 6 m

B150EP45/2 (2mt)  
B150EP45/3 (3mt)  
B150EP45/3.2 (3.2mt)  
B0150EP45/4 (4mt)  
B150EP45/6 (6mt)

**OPTIONAL**

## Kit pinze Clamps kit



### B150EK05

• Kit coppia pinze falso soffitto  
• Kit with pair of clamps on false ceiling.



### B110EK05

• Kit coppia pinze falso soffitto  
• Kit with pair of clamps on false ceiling.



## Accessori Accessories



### B150EKTS

• Kit Telescopico  
• Telescopic kit.

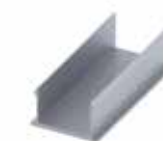

### B150EP45

• Copertura lato fisso  
• Cover fixed panel



### B150EP26

• Staffa di fissaggio a parete.  
• Wall fixing plate.

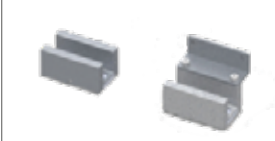

### BF50EKTS

• Guida a terra.  
• Floor Guide

## FLUIDO+

### Sistemas corredizos invisibles y compactos

Fluido+ 70, 110, 150 y Telescópico son los nuevos sistemas correderos compactos para puertas en vidrio templado. Espacios oscuros ya pertenecen al pasado: las nuevas exigencias son transparencia y espacios amplios. La mecánica resistente de los sistemas Fluido+ se funde perfectamente con su diseño moderno, garantizando seguridad, privacidad y claridad.

Diseñados para cumplir con las exigencias del mercado, son aptos para aplicaciones a pared, a techo y a falso techo. En la versión a falso techo el mecanismo está completamente escondido.

#### Características:

- Nuevo sistema de cierre progresivo – CPCS;
- Antichoque disponible;
- Ajuste frontal de la puerta sencillo y rápido;
- Capacidad hasta 150 kg;
- Enganche rápido entre riel y tapa;
- Disponible también para puertas de madera.

## FLUIDO+

### Systèmes coulissants invisibles et compacts

Fluido+ 70, 110, 150 et Téléscopique sont nos derniers systèmes coulissants compacts pour portes en verre trempé. Les murs sombres appartiennent au passé : les besoins modernes sont la clarté et les grands espaces. La mécanique résistante des systèmes Fluido+ se marie parfaitement avec leur design moderne, permettant sécurité, intimité et luminosité. Conçus pour répondre aux besoins du marché, ils conviennent aux installations au mur, au plafond et en faux plafond. Dans la version faux plafond, le mécanisme coulissant est complètement caché.

#### Caractéristiques:

- Nouveau système de fermeture progressive CPCS;
- Antichoc disponible ;
- Réglage frontal de la porte simple et rapide ;
- Capacité jusqu'à 150 kg ;
- Accouplement rapide du rail coulissant et du couvercle ;
- Disponible pour les portes en bois.

## FLUIDO+

### Unsichtbare und kompakte Schiebesysteme

Fluido+ 70, 110, 150 und Teleskopisches sind unsere neuesten kompakten Schiebesysteme für Türen aus ESG Glas. Dunkle Wände gehören der Vergangenheit an: Moderne Bedürfnisse sind Klarheit und viel Platz. Die widerstandsfähige Mechanik von Fluido+ -Systemen passt perfekt zu ihrem modernen Design und ermöglicht Sicherheit, Privatsphäre und Helligkeit. Konzipiert, um den Marktanforderungen gerecht zu werden, eignen sie sich für Wand-, Decken- und Zwischendeckeninstallationen. In der Zwischendeckenversion ist der Schiebemechanismus vollständig verborgen.

#### Eigenschaften:

- Neues progressives CPCS-Schließsystem;
- Antischock verfügbar;
- Vordere Einstellung der Tür, einfach und schnell gemacht;
- Tragfähigkeit bis zu 150 kg;
- Schnelle Kopplung von Gleitschiene und Abdeckung;
- Verfügbar für Holztüren.



Colcom Group Srl

Tel. (+39)0302532008 - (+39)0302530289

Fax. (+39)0302534707 [www.colcomgroup.it](http://www.colcomgroup.it)

Via degli Artigiani, n° 56 int. 1 - 25075 Nave (Brescia) - Italy

Member of the

**SIMONSWERK  
GROUP**