

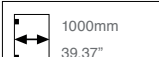

8015JC Biloba JC

colcom
OILDYNAMIC ■ REGOLABILE / ADJUSTABLE

MAX 80 Kg- 176 lbs

Porte - Doors

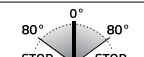
 8-10-12mm 5/16"-3/8"-1/2"	 1000mm 39.37"	 -15°C +5°F +40°C +104°F	 0° 80° STOP 80° STOP
--	--	--	---

▪ Cerniera oleodinamica (vetro-vetro 180°) con regolazione delle velocità di chiusura dell'anta e regolazione del punto 0. Corpo interno anodizzato, ossidazione profonda (20 micron) e copertina esterna in acciaio inox AISI 316. Stop a 0° +90° -90°.

▪ Bisagra cierra puerta hidráulica (vidrio-vidrio 180°) con ajuste de velocidad de cierre de la puerta y ajuste del punto 0. Cuerpo interior anodizado con tratamiento de oxidación con alto espesor(20 micron) y tapa exterior en acero inox AISI 316. Freno a 0°, +90°, -90°.

▪ Hydraulic hinge (glass to glass 180°) with adjustment of the closing speed of the door and zero point adjustability. Inner body is anodized with the special deep oxidation (20 micron) and cover made of stainless steel AISI 316. Stop at 0° +90° -90°.

▪ Hydraulischcharnier (Glas-Glas 180°) mit Feststellung der Türschließgeschwindigkeit und 0°-Punkt-Regulierung. Der innere Körper ist eloxiert mit Die Sonderoxydationsbehandlung (20 Mikron). Abdeckungen aus Edelstahl AISI 316. Feststellung bei 0° +90° -90°.

▪ Charnière hydraulique (verre-verre 180°) avec réglage de la vitesse de fermeture et réglage du point 0. Partie interne anodisée avec traitement d'oxydation profonde (20 micron). Capot externe en acier inox AISI 316. Arrêt à 0°, +90° et -90°.



Acciaio inox / Stainless steel : 31-32

APERTURE VIOLENTE OLTRE I 95° POTREBBERO CAUSARE LO SCARDINAMENTO. È CONSIGLIABILE L'APPLICAZIONE DI UN FERMAPORTA
VIOLENT OPENING FURTHER THAN 95° COULD UNHINGE THE DOOR
WE SUGGEST TO INSTALL A DOOR STOP



NON DOTATA DI FRENO ANTIVENTO ■ DISPONIBILE SU RICHIESTA ANCHE NELLA VERSIONE SENZA STOP A 90°. Versione da specificare in fase d'ordine e soggetta a possibili minimi d'ordine. Per ulteriori informazioni contattare l'ufficio commerciale.

NO ANTI-WIND BRAKE ■ AVAILABLE IN FURTHER VERSION WITHOUT 90° STOP. It have to be specified on being ordered and could be subjected to minimum quantity order. For further information, please contact the export department.

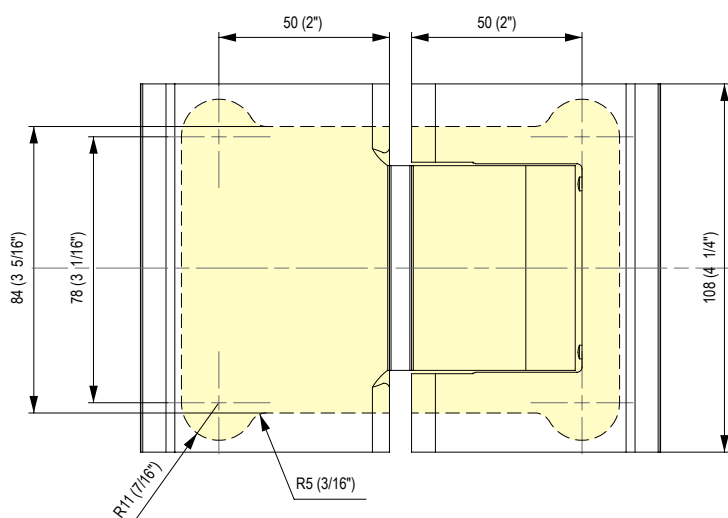

Classificazione secondo normativa - Clasificación según la ley - Classification according to int'l regulation Klassifizierung nach den Vorschriften - Classification selon la norme

art. 8015JCUNI EN 1154 : 2006	3	8	$\frac{2}{5}$	0	1	4
-------------------------------	---	---	---------------	---	---	---

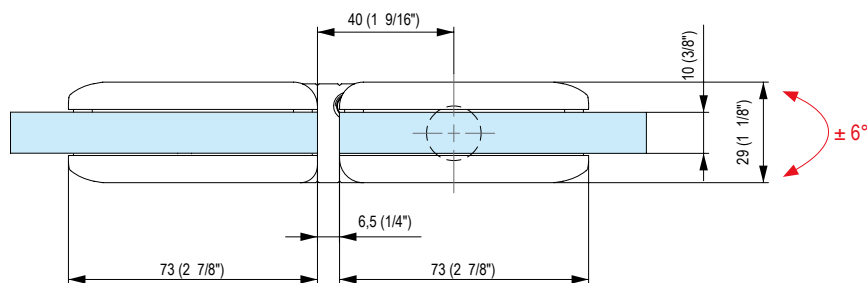
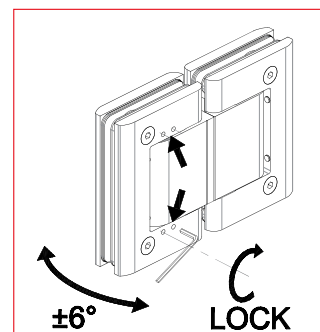

Valvola di regolazione velocità chiusura anta
Adjustment valve for the door's closing speed

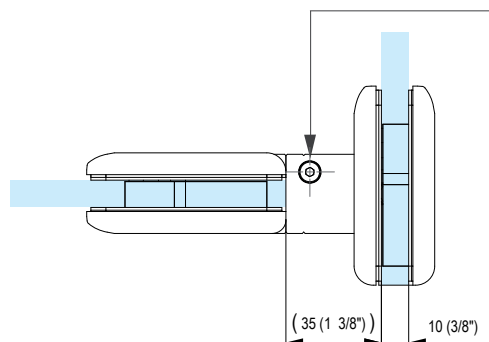

TESTATA 1.000.000 CICLI
TESTED FOR 1.000.000 CYCLES