

# V 2003

Designation : fixed bolt, cylindrical head, for installation from the outside



REFERENCE TO ORDER					
GLASS THICKNESS	Ø AXIS	LENGTH AXIS (MM)	LENGTH L	LENGTH X	ARTICLE CODE
6 ≤ V ≤ 22	M14	65	40	115±2	V2003-0622-1465
22 < V ≤ 26	M14	65	45	120±2	V2003-2226-1465

\* V2003-0622-1465 : Model - Glass Thickness - type axis and length

Sealing strip between glazing available p.8.26

## Dimensions

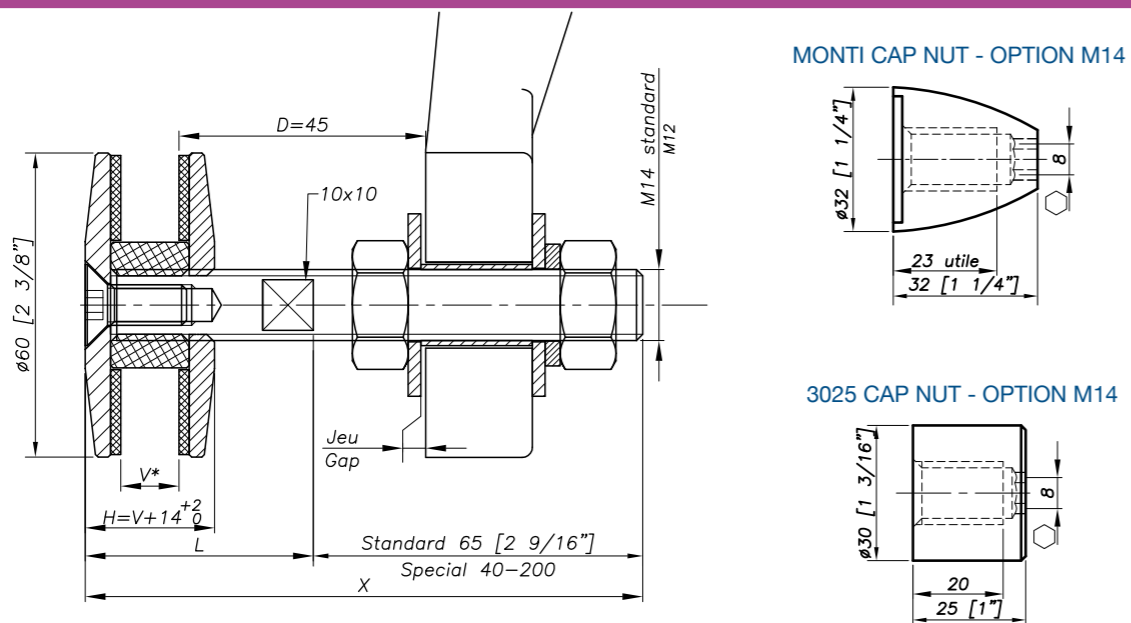

H= Swivel body corresponding to the thickness of the glass.  
V\* = glass thickness.

## Glass drilling

### MONOLITHIC GLASS

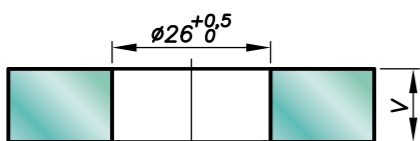

### LAMINATED GLASS

V = 1<sup>st</sup> glass + intercalated films + 2<sup>nd</sup> glass

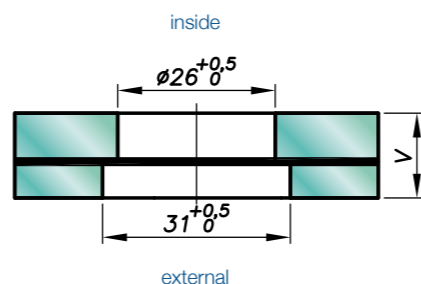

Available for glass thicknesses from 8 to 31.52mm, for other thicknesses please consult us.

It is important to provide the following information with each request : the glass composition (ex.: 10mm monolithic, 8.8.4 laminated, 8.8.2-12-10 insulating) / the length and diameter of the threaded axle if not standard dimensions (M14, 65mm) / the reference of the spider to be used as support, or the thickness of an existing support for the delivery of the spacer.

V 2003

## Mechanical performances

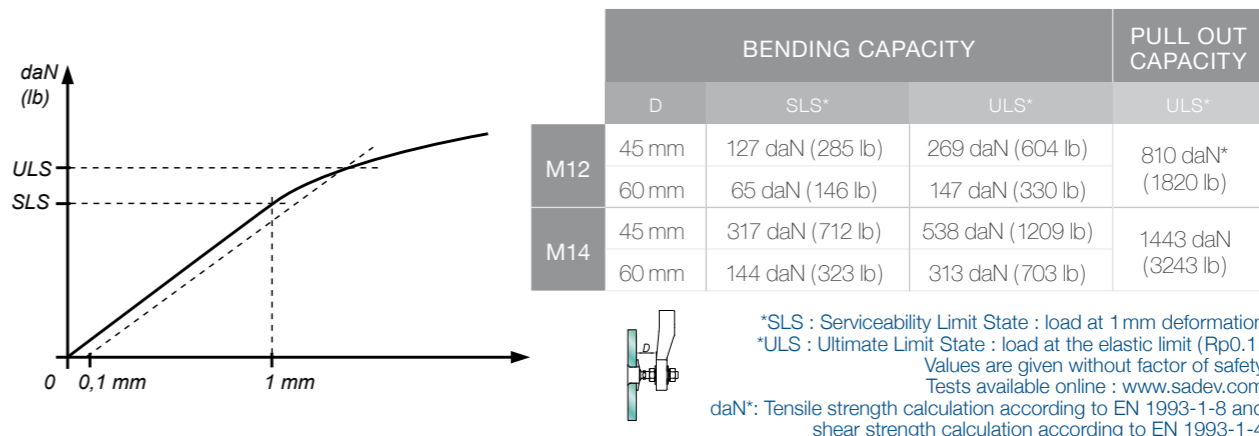

## Components

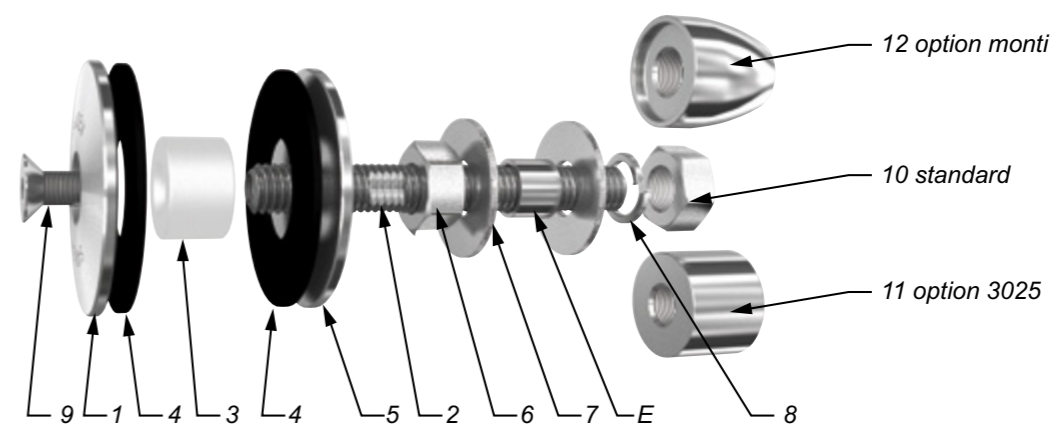

MARK	QUANTITY	DESIGNATION	MATERIAL
1	1	External plate	X2 Cr Ni Mo 17.12.2 as per EN 10088-3
2	1	Threaded axle	A4
3	1	Spacer Ø 25	Polyacetyl
4	2	Contact washer	EPDM
5	1	Glass nut Ø 60	X2 Cr Ni Mo 17.12.2 as per EN 10088-3
6	1	Nut DIN 934	A4
7	2	Washer	A4
8	1	Lock washer127	A4
9	1	Bolt DIN7991 M8x20	A4
10	1	Nut DIN 934	A4
11	1	3025 Cap Nut - Option	X2 Cr Ni Mo 17.12.2 as per EN 10088-3
12	1	Monti Cap Nut - Option	X2 Cr Ni Mo 17.12.2 as per EN 10088-3

## Suggested mounting instruction

### A – Classic mounting

Insert parts No.2/3/4/5 into the glass hole. Mount the second contact washer No.4, external plate No.1, and bolt No.9 and tighten to 20Nm (15 ft-lb) for monolithic glass and 10Nm (7.5 ft-lb) for laminated glass. Thread on nut No.6 and apply washer No.7. Insert the threaded axle into the support with spacer E (available on request), see technical page. Adjust the depth. Mount the second washer No.7, lock washer No.8, and nut No.10. Tighten to 60Nm (45 ft-lb) using a 22mm wrench.

### B – Blind mounting: installation from the outside (no access to the structure)

Mount nut No.6 and washer No.7 onto parts No.2/3/4/5. Insert the threaded axle into the support with spacer E (available on request), see technical page. Adjust the depth. Mount the second washer No.7, lock washer No.8, and nut No.10. Tighten to 60Nm (45 ft-lb) using a 22mm wrench. Set the glass onto the assembly, be careful not to put unprotected glass edges in contact with bare metal parts. Mount parts No.1/4 and 9 onto parts No.2/3/4/5 and tighten to 20Nm (15 ft-lb) for monolithic glass and 10Nm (7.5 ft-lb) for laminated glass using a 10mm wrench and a 5mm hex key.

SADEV recommends using thread locking compound whenever possible.